

Oracode Preventative Maintenance Steps



Cleaning the Oracode Lock

Clean and polish your locks every two months with a clean, dry cloth.

Important: Never use chemical cleaners or abrasives to prevent damaging the finish.



The keypads should be cleaned every two months to prevent the buttons from sticking. If your locks are exposed to high levels of dust or salt, the keypads should be cleaned more often.

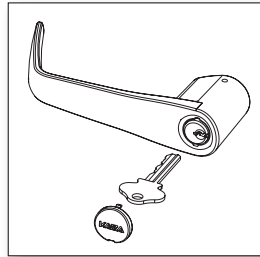

Testing and Inspecting the Oracode Lock

Test all override cylinders every month, especially in humid environments, to ensure that emergency access is possible when required.

Inspect the doors to ensure that the door-to-frame alignment is correct. The latch bolt must engage the strike, and the gap between the door and the frame should

be small enough to allow the strike to depress the auxiliary latch.

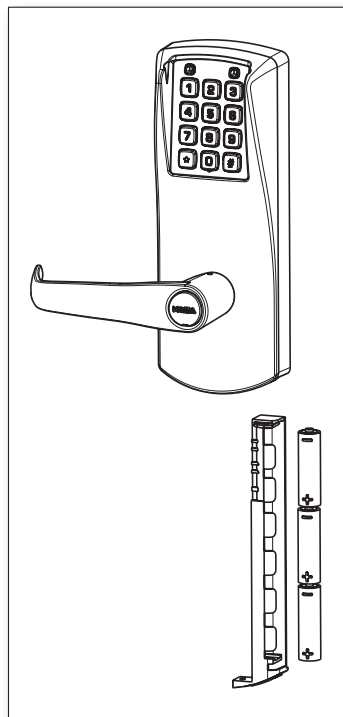

Replacing the Batteries

The Oracode lock requires three AA alkaline batteries, which will last for approximately 120,000 entries. A low-battery indicator will flash a warning when the battery has enough power left for only 2,000 openings.

Replace the batteries as shown in the illustration. If the batteries are removed and not replaced within ten minutes, the lock will have to be reprogrammed.

Important: Use only alkaline batteries.

dormakaba Customer Services & Support

Phone: 888.217.5654

General Information: www.dormakaba.com